



NCS MANURE SEPARATOR MODEL AQ2000D



**The Premier Resource
for Manure
Treatment and
Total Nutrient Control**

MANURE SEPARATION

WHY SEPARATE?

Problems with manure management constitute the greatest challenge facing producers today. Conventional slurry systems are odorous, pose environmental risks, clog and compact the soil, require high HP pumps and agitators and do not allow for further treatment steps.

Solids separation is the universal first step in primary waste treatment, paving the way to meet the following objectives:

Increased lagoon life
Improved flush water
Composting for profit
Easier pumping
Higher crop yields
Improved soil quality
Eliminate tanking
Eliminate odor problems
Total control of nutrients

Reduced storage needs
Reduced solids build-up
Reduced nutrients in liquid
Reduced HP inputs
Reduced environmental liability
Minimize pipe clogging
Eliminate run-off
Improve nutrient up-take
Save 50% over tanking

Ability to flush
Composting for bulk reduction
Meet regulations
Ability to irrigate or PulseJet
Meet N or P based plans
Reduced BOD and COD
Expand herd size on the same land
Eliminate soil compaction
Reduce labor inputs

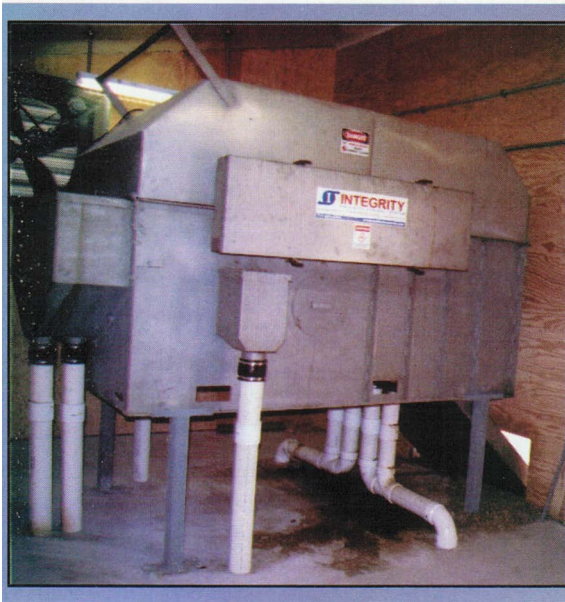

WHY CHOOSE THE NCS SEPARATOR?

The NCS Manure Separator combines both static screen and roller press technologies for efficient removal of solids. The separation process occurs within the machine to eliminate splashing and mess while the simple mechanicals are totally accessible beneath hinged covers. Spring-loaded rollers are adjustable to achieve desired solids and will harmlessly roll over foreign objects without damage to the machine. With processing capacity from 40-400 GPM, the NCS Separator works well with all manure inputs, scrape or flush. Compact and efficient, it can be easily housed for year round, trouble free operation. The NCS Separator is constructed entirely of heavy stainless steel and uses lubrication free bearings and rollers. The machine does not require frequent cleaning and is virtually maintenance free. The NCS Separator has a five (5) year limited warranty.

OTHER IMPORTANT FEATURES INCLUDE:

- All stainless construction. Chassis and frame are 3/16" stainless steel.
- Hinged lids provide unlimited access to internal mechanicals and are easily removable.
- Easily adjustable nylon brushes convey solids and keep screens clean.
- Rollers and bearings are corrosion-proof and require no maintenance or lubrication.
- Influent volume readily adjustable at Separator without adjusting pump output.
- Screens are easily replaceable and available in different pore sizes for optimum flexibility.
- Economical 1.5 HP electric motor with safety switch on hinged lids.
- Top mounted collar for ducted air conveniently ties to heat source to prevent freezing.
- Models for Dairy, Swine, Poultry, Confined Beef and Food Processing.
- INTEGRITY Separator Control Package, Pumps and Agitators available.
- Lease through NCS Leasing.

ENGINEERING



Above Ground Reception With Drive-Under Separator Building.



Drive-Under Separator Building With Solids Management Pad.



Separator House With Stacking Auger And Covered Composting Pad.



Separator House Directly Over Reception Pit With Stacking Pad.



Mechanical Space Between Separator (Above) & Reception Pit (Below).



Housing For Sand & Solids Separation With Horizontal Auger & Stacking Pad.



Park-Under Separator And Solids Management Pad.



Post Separation Clarification Cells For Further Phosphorous Reduction.



Separator & Solids Management In Former Commodity Shed.

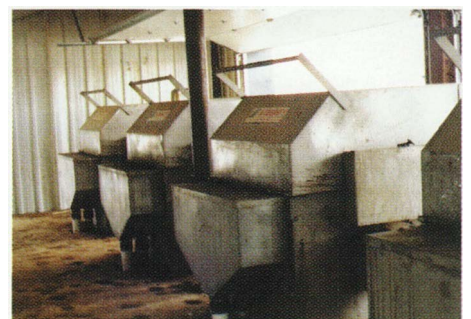

Multiple Separator Installation.

INSTALLATION

PLAN VIEW

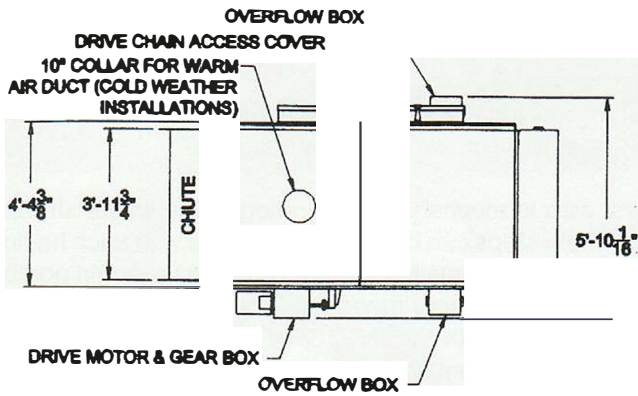

RESTRICTED PLAN VIEW

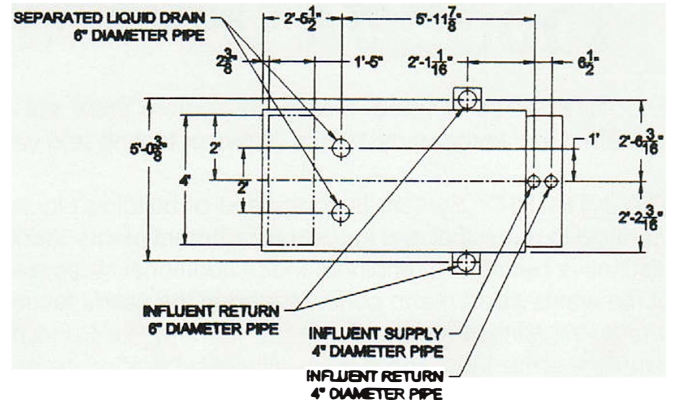

SIDE ELEVATION

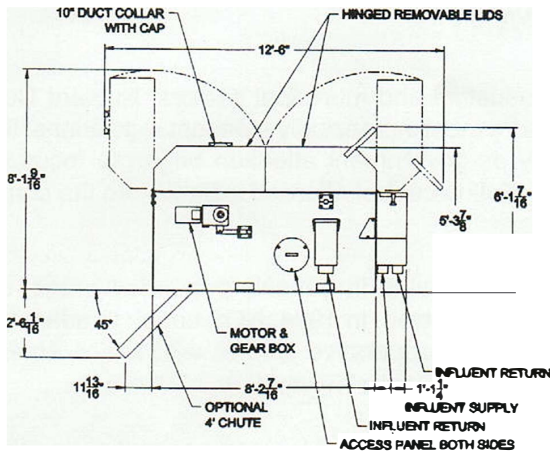

OPERATIONAL CROSS SECTION

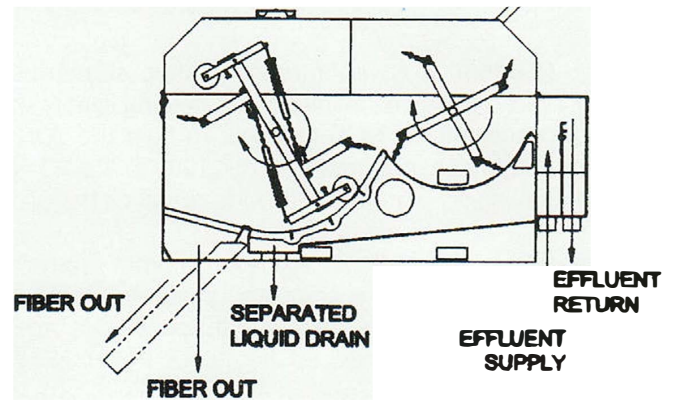

SUGGESTED CONTROLS

HIGH/HIGH LEVEL	Triggers alarm and/or activates optional back-up pump and/or shuts-down flush system.
HIGH LEVEL	Starts separator, agitator, (conveyors) and delivery pump. Pump on a 5 minute time delay.
LOW LEVEL	Stops separator, agitator, (conveyors) and delivery pump. Separator and conveyors on a 5 minute time delay.
MANUAL ON/OFF	Manual over-ride for each piece of equipment.
PANIC	De-activates entire system.

NOTES

- Drive Motor – 1.5 HP, 208/230/460 3 Ph (1 Ph optional)
- Dry weight – 3,000# Wet weight – 3,400 #
- Piping can be PVC with rubber couplers and clamps
- Long radius ells are suggested
- Separator Control Package available
- Stainless float switches recommended
- Housing recommended for cold climates

EXAMPLE

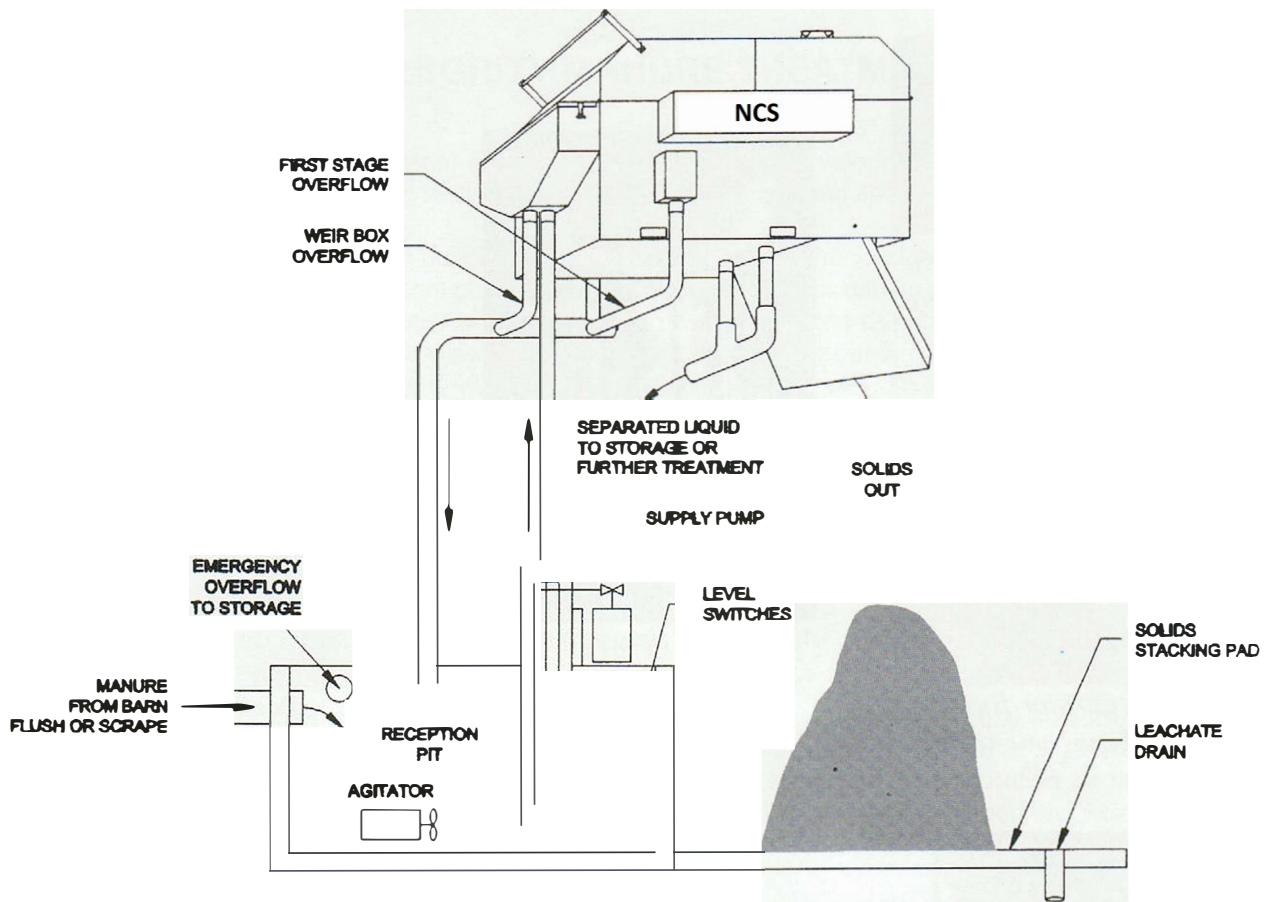

OPERATIONAL SCHEMATIC

NORMAL OPERATION – Manure, scraped or flushed, enters the reception pit from the barn, usually by gravity. As the level rises in the pit, the high-level float switch activates the separator, agitator (essential), optional conveyors and pump. Pump is on a 3-5 minute time delay to allow thorough agitation. The pump then activates supplying manure (influent) to the weir box on the end of the Separator. The weir box has two chambers, a supply chamber and a return chamber separated by a weir that easily adjusts up and down. The height of the weir determines how much influent is permitted to flow into the machine for processing versus how much returns to the reception pit. This eliminates the need to adjust the pump output. The influent flows into stage one of the Separator where the liquid portion falls through a static screen. The solids are left behind to be brushed into the second stage. There, the solids are pressed with a roller before being brushed to the discharge. Solids can fall vertically from the machine directly into a spreader or onto a concrete slab, or they can fall onto a chute or conveyor. Separated solids can be stored and land applied, or composted and sold. The liquid portion of the waste stream exits beneath the machine and is directed toward storage or additional treatment. When the level in the reception pit drops to the low level float switch, the separator, agitator and pump are deactivated. The Separator and conveyors are on a 3-5 minute time delay to allow adequate purging.

OVERFLOW PROTECTION – There are safeguards that should be designed into the separation system to assure that the reception pit does not overflow. There are a number of simple safeguards that can be used singly or in combination. For instance, a high/high-level float switch can be used to activate a second back-up pump, sound an alarm, and/or shut down the flush system. Another important safeguard is an emergency high level overflow outlet to safely by-pass the separation system directing manure straight to storage. This is an important safeguard even if other mechanical safeguards have been installed.

SIZING THE RECEPTION PIT – Scraped Manure Applications – for design purposes, calculate the pit size using a Separator capacity of 45 GPM and design to the worst case scenario. Parlor liquids must be included for proper operation and the influent must be at least 93% liquid. Flushed Manure Applications – for design purposes, calculate the pit size using a Separator capacity of 225 GPM and design to the worst case scenario. Do not hesitate to contact the company for help with these calculations.



ABOUT THE NCS MANURE TREATMENT SYSTEM

The NCS Manure Treatment System grew out of research and development undertaken by Nutrient Control Systems, Inc. in the early 1990's. Years of testing and validation won academic and regulatory approval.

The NCS System is comprised of building blocks. The first step is mechanical separation of the waste stream, identical to municipal and industrial treatment plants. Additional treatment steps can be added as desired with each having distinctive benefits. Combined, these additional steps result in most of the nutrients being removed from the liquid portion of the waste stream and concentrated in the solids fraction where they can be easily managed. The treated liquid fraction has a low, stabilized and balanced nutrient level and can be land applied with the NCS PulseJet. The key is controlled-rate land application. While separation alone affords many important benefits, a total NCS Manure Treatment System goes even further to eliminate odor and run-off. The System can permit herd expansion on an existing land base and meet N or P based nutrient plans. Installation of the total System pays for itself because it virtually eliminates tanking and manages waste at ½ the cost per gallon. The INTEGRITY Manure Treatment System is changing everything! Call for an explanation of how the system works and where the nutrients go.

ABOUT THE COMPANY

Through the 1980's, environmental cleanup efforts focused on the industrial and municipal sectors. Nutrient Control Systems, Inc. (NCS) was involved with helping clients within those sectors meet increasingly stringent regulations. It was a natural transition for NCS to begin to help the agricultural industry as government attention began to focus upon concentrated animal operations in the 1990's. A solid background in pollution control afforded insights into the complex problems facing producers. Worldwide research began to yield solutions.

In Europe, for instance, concentrated animal operations are commonly located in densely populated areas. Strict regulations were already in place and innovative technologies had already evolved. In 1994, NCS began to adapt these technologies to American agricultural operations. Additional research and cooperative studies with major American Universities ultimately produced the unique NCS Dual Stream Nutrient Control System.

Today, NCS leads the world in animal waste management technology. Research and development continues with the cooperation of Universities, forward thinking producers and the Regulatory community. The Nutrient Control System is expanding to include sand separation, methane digestion, advanced wastewater treatment processes and other means to isolate nutrients and bring animal waste treatment to whatever level is necessary for regulatory compliance.

The professional staff at NCS is licensed, certified and experienced in important areas such as soil science, nutrient planning and industrial/commercial wastewater treatment. NCS also has broad experience working with regulatory agencies to secure the documentation and approvals often necessary to allow system and equipment installation.

NCS has worked extensively with academia to validate the concepts and equipment that make-up the Nutrient Control System. It is versatile, flexible, affordable and effective. In fact, it is the first and only complete manure/ nutrient management program on the planet.



Call Us Today for a FREE QUOTE!

717.261.5711

www.ncsysinc.com

info@ncsysinc.com